

**rotork**<sup>®</sup>  
Fluid Systems

## Skilmatic Range



Electrically Operated  
Spring-Return Actuator Range

Redefining Flow Control

The   
**SKILMATIC**<sup>®</sup>  
 Range

## Contents

Section	Page
Skilmatic Product Overview	3
SI-EH Quarter-turn Actuators	4
SI-EH Linear Actuators	5
Partial Stroking	6
SIL Solutions	7
Insight2 Intelligent Software	8
Modulating Control	9
Principles of Operation	10-11
SB General Purpose Actuators	12
Bus Control Systems	13
Industrial Applications	14-15
General Specification	16
Hazardous Area Certifications	17
Rotork Site Services	18
Case Study	19



Rotork is the global market leader in valve automation and flow control. Our products and services are helping organisations around the world to improve efficiency, assure safety and protect the environment.

We strive always for technical excellence, innovation and the highest quality standards in everything we do. As a result, our people and products remain at the forefront of flow control technology.

Uncompromising reliability is a feature of our entire product range, from our flagship electric actuator range through to our pneumatic, hydraulic and electro-hydraulic actuators, as well as instruments, gear boxes and valve accessories.

Rotork is committed to providing first class support to each client throughout the whole life of their plant, from initial site surveys to installation, maintenance, audits and repair. From our network of national and international offices, our engineers work around the clock to maintain our position of trust.

**Rotork. Redefining flow control.**

## Skilmatic Product Overview

The Skilmatic range of self-contained electro-hydraulic actuators, combine the simplicity of electrical operation with the precision of hydraulic control and the reliability of mechanical fail-safe action.

The new highly intelligent SI/EH *Pro* control and monitoring system is based on the well proven Rotork IQ *Pro* actuator. SI/EH *Pro* actuators provide the ideal solution for two position control, critical safety shutdown or precise modulating control.

SI/EH *Pro* provides the benefits of reliable valve actuation by combining existing proven Skilmatic features with new text displays, performance monitoring and datalogging - including valve signature profiles. In combination with Rotork's non-intrusive intrinsically safe Bluetooth<sup>®</sup> Setting Tool *Pro*, the actuator configuration and datalogger files can be transferred from the field to the office for download, analysis and storage.



**Insight2**

### SI/EH *Pro* – Improved monitoring and control:

- Datalogger – Recording events, trends and alarms.
- Bluetooth<sup>®</sup> Setting Tool *Pro* – Data download and upload between SI/EH actuators InSight2 software.
- Semi-automatic position limit calibration.
- Partial stroke – Activated remotely or locally with the Setting Tool *Pro*.
- Optional ESD manual reset – To restrict the actuator from operating until locally reset when the process is in a safe condition.
- Independent deadband and hysteresis – Improved position control for analogue modulating applications.
- Valve flow characterisation – For modulating control with various valves characteristics such as linear, equal % or quick opening trim.
- Optional over pressure & under pressure hysteresis adjustment.
- Manual override detection.
- Position maintained – in any position for digital control and network options.
- CPT output can be configured to provide a 4-20 mA output signal for valve position or actuator hydraulic pressure.
- Independent alarm output relays – Selectable alarm and monitoring function.
- Temperature sensor – Monitoring the internal temperature of the actuator.

### SI *Pro* and EH *Pro* offer a range of enhanced features:

- Larger clearer dual display with 32 character text.
- Valve torque / thrust signature and profile measured and recorded in the form of actuator hydraulic back pressure.
- Status & monitoring diagnostics.
- Improved data download and transfer speed via Bluetooth.
- Compatible with Rotork InSight2 software.
- Compatible with Rotork network communication cards – Pakscan, Profibus<sup>®</sup>, Foundation Fieldbus<sup>™</sup>, Devicenet<sup>®</sup> and Modbus<sup>®</sup>.

## SI-EH Quarter-turn Actuators

The Skilmatic SI/EH-Q product range offer a unique and reliable solution for electric fail safe and modulating control of quarter turn valves and dampers.

The range consists of two product categories, the SI-Q actuators are designed as a standard range with low internal hydraulic pressure for torques from 65 Nm to 4400 Nm. The EH-Q actuators are custom built to suit specific applications with a higher internal hydraulic pressure for torques up to 600,000 Nm

Specifically designed for safety critical applications the actuators accept various inputs signals as standard, including emergency shutdown (ESD) and partial stroke testing (PST). Optional field bus communication can be provided for remote monitoring and control. The SI/EH actuators are available for use with various power supplies, single phase, three phase or 24 VDC.



The SI-Q are compact and robust spring return actuators designed for all types of ball, butterfly, plug valves and dampers. Consisting of a self-contained electro hydraulic power module with a spring return scotch yoke drive the actuators are available as spring return clockwise, anti-clockwise or lock in last position. The SI actuators can also be configured for modulating control with a positioning resolution <0.2%.



The EH-Q offer the flexibility to customise the actuators to suit specific applications and process conditions. The actuators are self-contained and utilise a higher internal pressure to drive a double acting or spring return scotch yoke drive. Eliminating the high installation and maintenance costs associated with conventional electro-hydraulic systems which utilise central hydraulic power units. Optional accumulators are offered to provide an alternative to spring return fail safe, multiple stroking and a means to decrease the hydraulic speed.

### SI-EH Quarter-turn Performance Data

Actuator	Spring end Torque (Nm)		Spring Speeds (sec)			
	From	To	Hydraulic Direction		Spring Direction	
			From	To	From	To
<b>Quarter-Turn</b>						
SI-1-Q	65	480	15	95	1.5	30
SI-2.1Q	380	4,400	14	110	8	110
EH-Q-SR*	4,000	210,000	5	425	2	200
EH-Q-DA**	1,000	600,000	5	325	N/A	N/A

\* SR = Spring-Return  
 \*\* DA = Double-Acting

# SI-EH Linear Actuators

The Skilmatic SI/EH-L product range provides a reliable solution for electric fail safe and modulating control when a direct linear drive is required.

The range consists of two product categories, the SI-L actuators are designed as a standard range with thrusts from 1.7 kN to 61 kN. The EH-L actuators are custom built to suit specific applications with thrusts up to 150 kN spring return or 5,500 kN double acting.

For modulating control the deadband and hysteresis can be independently adjusted in both directions to optimise the positioning accuracy and repeatability. The output position against demand profile can also be characterised within the actuator program to suit the valve flow characteristics such as linear, equal % or quick opening. The SI/EH actuators are available for use with various power supplies, single phase, three phase or 24 VDC.



The SI-L are robust electrically operated linear actuators designed for modulating control but are equally suited for two position control. The power module provides a pulsed hydraulic output to accurately position the spring opposed linear cylinder, they are available as spring extend, retract or lock in last position on loss of power or control signal. The SI-L actuators accept an analogue input signal to accurately position a control valve with a resolution < 0.2%, they will also provide a 4-20 mA output of valve position.



EH-L actuators offer the flexibility to suit specific applications and are designed for two position and emergency shutdown applications. The actuators can also be configured for analogue control with a resolution of < 0.5% with the option of slow mode. They are available as spring return to extend or retract or double acting for fail safe or lock in last position on loss of power or control signal. Optional accumulators and various hydraulic pump sizes are available to suit the required operating speeds and fail safe action.

## SI-EH Linear Performance Data

Actuator	Spring end Thrust (kN)		Spring Speeds (mm/sec)			
	From	To	Hydraulic Direction		Spring Direction	
			From	To	From	To
<b>Linear</b>						
SI-1-L	1.7	10	4	0.6	40	1.62
SI-2.1L	10	61	4.2	0.8	14	0.8
EH-L-SR*	25	150	300	0.5	300	0.5
EH-L-DA**	10	5,500	300	0.5	N/A	N/A

\* SR = Spring-Return  
 \*\* DA = Double-Acting

# Partial Stroking Testing (PST)

Partial Stroke Testing (PST) is a technique used in Safety critical applications where the safety valve is infrequently operated. PST allows the operator to test a percentage of possible failure modes of the actuated shutdown valve. The test can be performed without the need to physically close the valve and thereby maintain production. This procedure, allows the user to identify any faults which could potentially prevent the actuated valve performing its safety function.

The Rotork SI/EH offer an electrically powered fail safe actuator for use in safety applications where PST is required to test the availability of the valve. The Rotork SI/EH spring return actuators provide Partial Stroking as standard. When the command is given to initiate the test the actuator will move the valve to a preset position and the time taken will be measured and compared to the original time recorded at the commissioning stage. The internal pressure is also measured and recorded. A pass or fail will be given when the test has been completed.

## Partial Stroke Testing (PST)

The Rotork SI/EH advanced PST system operates by de-energising each solenoid valve in turn to allow the valve to move to the required position and then return the valve to the open state. The degree of movement required is configured by the user during the commissioning process and is adjustable from 0 to 99%.

## Safety Performance

At higher SIL levels (SIL2 & SIL3) it is common that the calculated maximum allowable time between compulsory shutdowns is too short to allow the plant to operate to an acceptable level for production. In these cases partial stroke testing can be an invaluable tool to allow the operator to test the valve on-line and take a credit for proving the performance of the valve. Dependent upon the quality and frequency of the test the calculated maintenance shutdowns intervals can be extended. This not only improves the safety performance of the plant but also improves production performance.

## Diagnostics

When the SI/EH intelligent PST technique is used, along with improving safety the operator can also gain information relating to the performance of the valve and actuator assembly. The PST system monitors the hydraulic pressure, which directly relates to torque or thrust needed to move the valve, and the time taken to travel to a pre-determined position. This provides the user with a high level of diagnostic data on all critical components within the actuator including the solenoid valves.

## ESD (Emergency Shut Down)

In the event of the ESD signal being de-energised or "tripped" the actuator and valve will move to the pre-determined safe position as determined by the return spring. The ESD tripped signal will override all other commands.

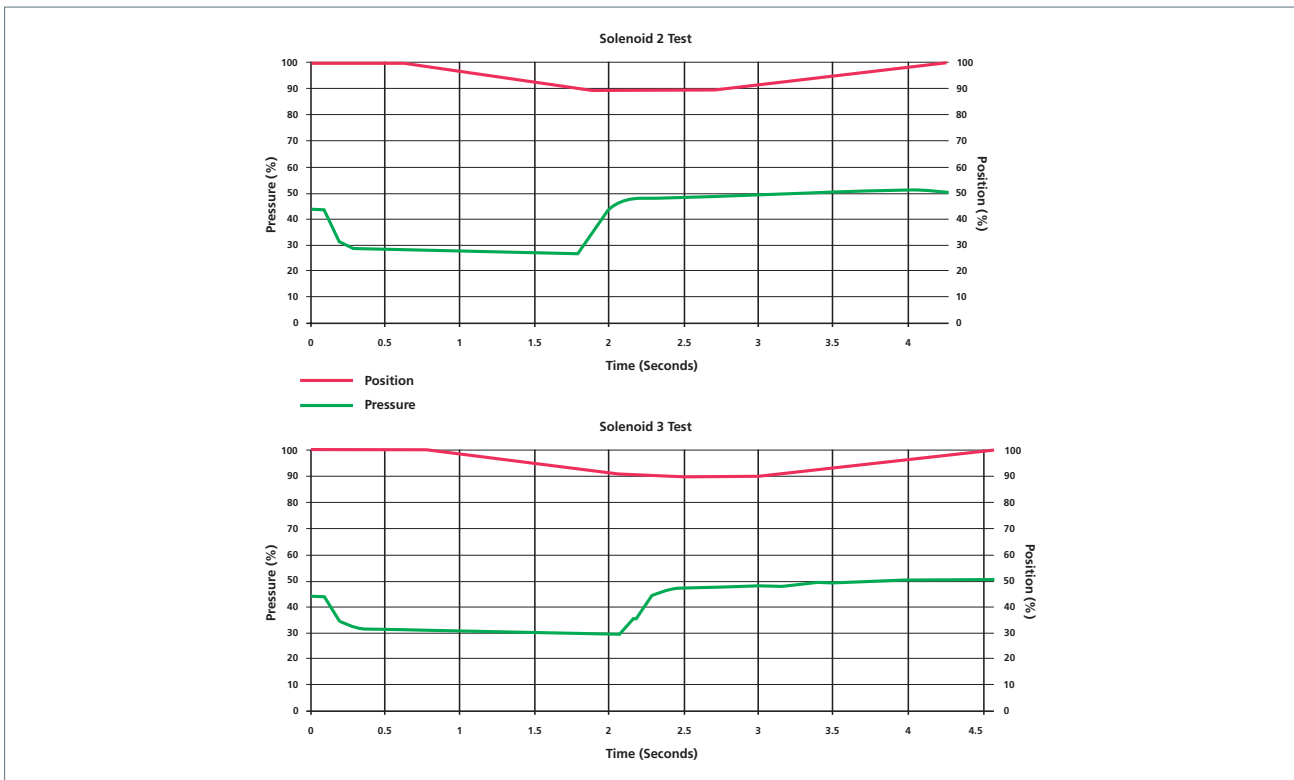

# SIL Solutions

Safety Integrity Levels are part of a larger scheme called Functional Safety that deals with techniques, technologies, standards and procedures that help operators protect against hazards.

Functional Safety adopts a life cycle approach to industries that deal with hazardous processes. The requirement to meet a given SIL level is becoming increasingly common in many industrial process environments. Assessing the performance of the final elements can be a complex process, however manufacturers can assist by having products independently certified as "Suitable for Use" at particular SIL levels by independent organisations such as TÜV. Ultimately the end user must still conduct all the necessary calculations to ensure that the system as a whole adheres to the requirements for the SIL level.

SI and EH Electrically operated, spring-return actuators are ideal for use in safety systems or any critical loop application where SIL 1 to SIL 3 are a requirement. Both SI and EH have been verified by TÜV Rheinland to comply with SIL Levels 2 & 3. The actuators also provide a Partial Stroking capability as standard to extend the period between planned shutdowns and provide improved SIL ratings through regular testing.

Rotork can offer a range of other TÜV certified products, please see the Rotork SIL Product & Services literature.

### Certified Personnel

- TÜV certified Functional Safety professionals
- International network of IEC 61508 specialists



### SI (Electro-Hydraulic Spring-Return Actuators)



SIL Rating	SI-1		SI-2-1	
	2	3	2	3
Hardware Fault Tolerance (HFT)	0		0	
Safe Failures ( $\lambda_S$ )	776		746	
Dangerous Failures ( $\lambda_D$ )	148		126	
Dangerous Detected Failures ( $\lambda_{DD}$ )	126		141	
PFD <sub>AVG</sub>	649,000	83,100	463,000	65,900
Safe Failure Fraction (SFF)	84%	98%	84%	98%
Hardware Type	A		A	
Partial Stroke	0	1/month	0	1/month

### EH (Electro-Hydraulic Spring-Return Actuators)



SIL Rating	3
Hardware Fault Tolerance (HFT)	0
Safe Failures ( $\lambda_S$ )	4,270
Dangerous Failures ( $\lambda_D$ )	379
Dangerous Detected Failures ( $\lambda_{DD}$ )	341
Safe Failure Fraction (SFF)	99.2%
Hardware Type	A

#### Notes:

1. All failures rates are  $10^{-9}$  failures/hour.

## Insight2 Intelligent Software

Rotork Insight2 facilitates the review, configuration and analysis of set-up configuration and data logger information for Rotork Bluetooth® enabled actuators. The visually interactive application is intuitive with clear menus making it a simple and fast process.

### Bluetooth® Setting Tool Pro

The Bluetooth Setting Tool *Pro* allows downloading and uploading of data logger and configuration files. The tool is intrinsically safe and can be used in hazardous areas. File transfer and data exchange is made over Bluetooth between the Setting Tool and PC and between the Setting Tool and the actuator.

Rotork IQ3, Skilmatic Range EH *Pro* and SI *Pro* actuators all support Bluetooth communication. Insight2 requires a PC with a Bluetooth interface running Microsoft™ Windows XP or newer.

### Data Logging

Rotork Bluetooth enabled actuators include an onboard data logger. The data logger captures and stores valve, actuator, control signal operation and status data which can be viewed on a PC using Insight2. Log data is time and date stamped and can be viewed on an event by event basis.

### Missions

Insight2 enables the user to pre-configure actuator missions on a PC, transfer them to a Bluetooth Setting Tool *Pro* and transmit them out in the field to the actuator. The missions can be dedicated to specific actuators by type or serial number.

Standard missions include:

Extraction of Actuator Configuration & Datalogger.  
Modification of actuator and option configuration.

### Security Protocols

Password protection is available on the Insight software and actuators to prevent unauthorized or accidental modification of actuator configuration parameters.

### Features:

- View and Modify actuator specification and configuration on PC.
- Valve and Actuator starts against position log.
- Valve torque profile, open/closed instantaneous and average torque against valve position.
- View and Modify option card configuration.
- Operation and Actuator control status log.
- Pre-configure missions on PC and transfer them to actuators in the field via the Bluetooth Setting Tool *Pro*.

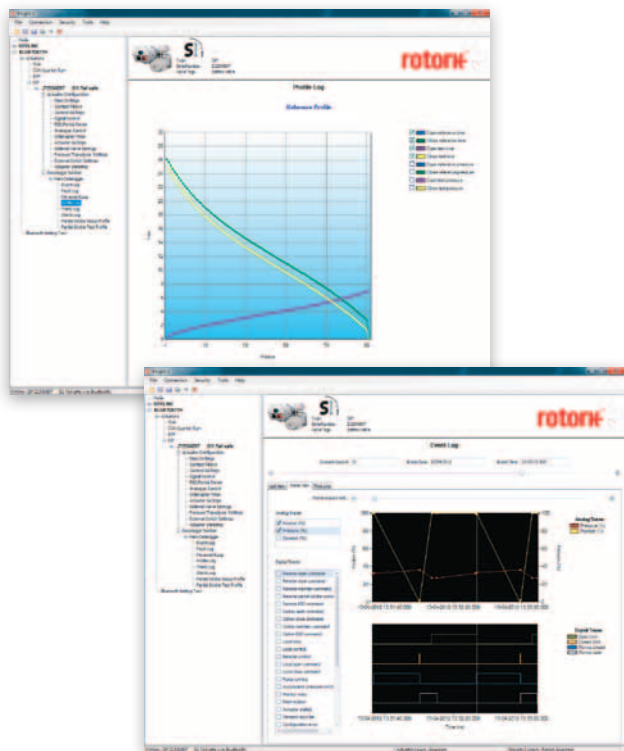



# Modulating Control

SI and EH intelligent actuators have been specifically designed to provide electrically operated actuation for modulating control applications. They will provide accurate control of linear and quarter-turn control valves or dampers with the option to lock in last position or fail safe spring return on loss of power supply or control signal.

Skilmatic actuators will accurately position a control valve with a resolution better than 0.2% from an analogue 4-20 mA input, digitally pulsed or through our range of fieldbus communication interfaces. The actuator range will also provide a 4-20 mA output of valve position which can be internally or externally powered.

Utilising the Rotork infra red / Bluetooth® setting tool the actuators can be easily configured to accept various inputs, outputs, control and alarm functions without removing any electrical covers thereby minimising the risk of moisture ingress and allows for full monitoring of the alarms and settings of the actuator in hazardous areas.

For modulating control applications there are a number of specific features built in the Skilmatic range to provide a flexible and accurate control to suit specific valves and applications

### Independent deadband and hysteresis

The deadband and hysteresis can be independently adjusted in both the opening and closing directions to optimise the control to suit the process. This allows for a more flexible approach to allow for various spring return speed to meet the specific application and provide optimum positioning control.

### Flow characterisation to suit the specific automated control valve

Utilising the Rotork InSight2 software the actuator position against demand profile can be tailored to suit the specific valve flow characteristic such as linear, equal percentage, and quick opening valve trim.

### Modulating with ESD Fail safe action.

The Skilmatic actuators can be supplied to lock in position or fail safe to close or open the valve on loss of power or control signal. The actuators can also be configured to provide an emergency shutdown (ESD) function, when configured the ESD signal is independent and would take priority over the modulating circuit.

The datalogger combined with the Rotork InSight II software provides a means to analysing the process trends. The analogue input signal to valve position feedback traces can be compared together with the thrust / torques through the actuator hydraulic pressure measurement.

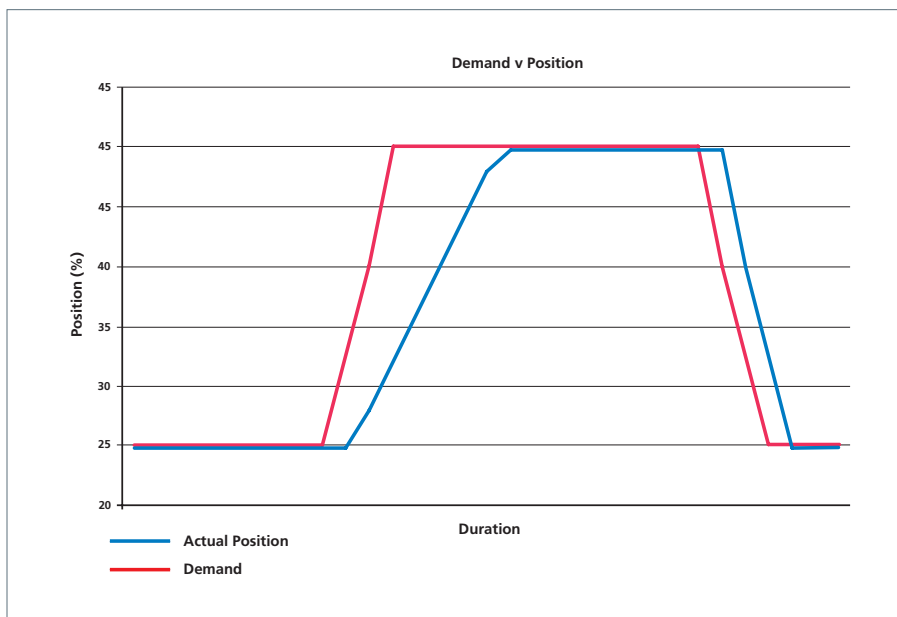



# Principles of Operation

## SI-1 Actuators

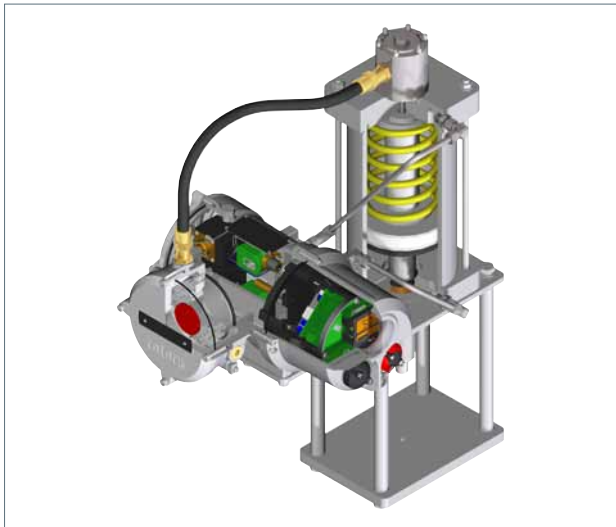

The actuators operate on a pump and bleed principle and utilise the Skilmatic dual oscillating pumps to provide instantaneous hydraulic pulses in one direction and spring-return in the opposite (bleed) direction, providing inherently accurate control.

### Actuator commanded to Open from the Closed limit.

The bleed solenoid valve(s), and pumps are energised. The system pressure acts against a spring opposed piston to drive the actuator in the open direction.

### Actuator commanded to Stop, or reaches the Open limit.

The pumps are de-energised and the bleed solenoid valve(s) remain energised, the system pressure is maintained to hold the actuator position.

**Actuator commanded to Close, reach the Closed limit or loss of ESD.** The bleed solenoid valve(s), and dual oscillating pumps are de-energised. Pressure is released; the hydraulic fluid returns to the reservoir and the springs return the drive shaft to the closed or safe position.

## SI-2 Actuators

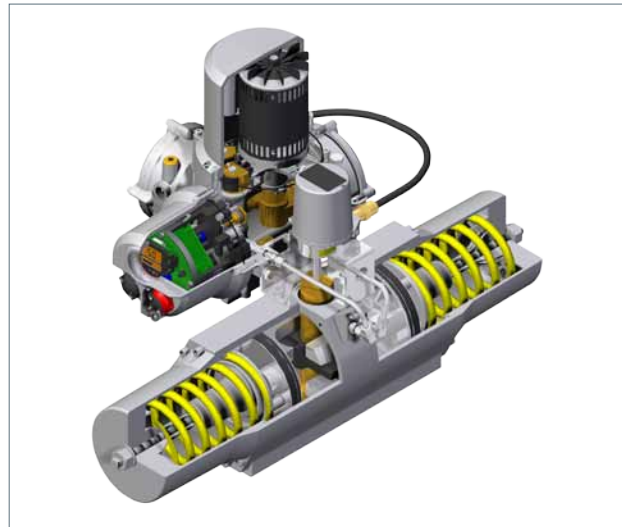

The actuators operate on a pump and bleed principle utilising a motorised vane pump to provide hydraulic pressure in one direction and spring-return in the opposite (bleed) direction.

### Actuator commanded to Open from the Closed limit.

The bleed solenoid valve(s) are energised. The motorised vane pump is started under no-load condition as a result of the delay in energising the by-pass solenoid valve. With the by-pass solenoid energised, the system pressure acts against a spring opposed piston to drive the actuator in the open direction.

### Actuator commanded to Stop or reaches the Open limit.

The by-pass solenoid valve is de-energised, followed by the motorised vane pump after 5 seconds unless a new command to Open is given. The bleed solenoid valve(s) remain energised and the system pressure is maintained to hold the actuator position.

### Actuator commanded to Close, reach the Closed limit or loss of ESD.

The by-pass solenoid valve, bleed solenoid valve(s), and motorised vane pump are de-energised. Pressure is released; the hydraulic fluid returns to the reservoir and the springs return the drive shaft to the closed or safe position.

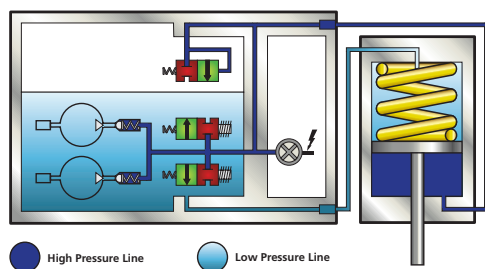

\*Diagram shows Linear configuration

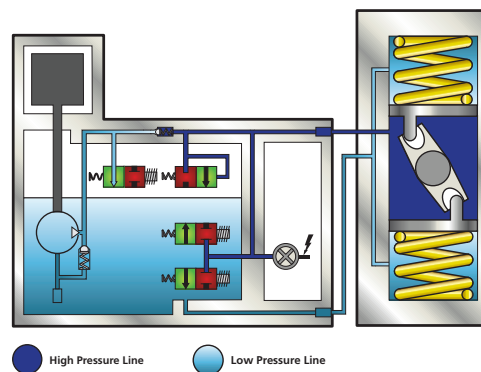

\*Diagram shows Quarter-turn configuration

# Principles of Operation



## EH Actuators

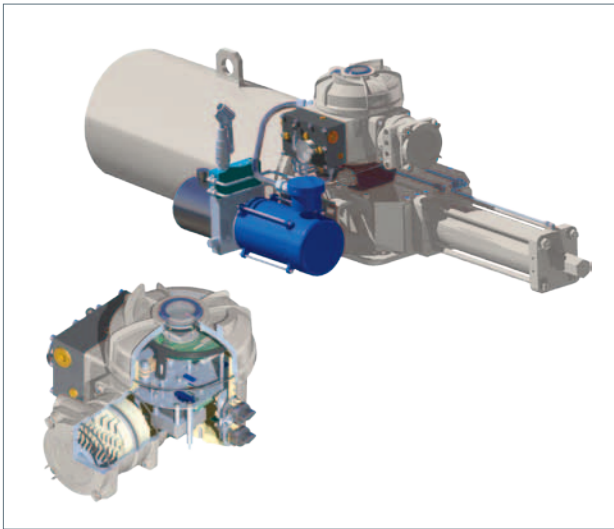

### Spring-return

During the opening cycle, the motor turns on and drives the hydraulic pump. The bypass solenoid valve allows the pump to get up-to-speed under no load. When the motor is at full speed, the bypass valve shuts and hydraulic fluid is forced into the actuator cylinder moving the actuator to the open position. In an on/off application, to move the actuator to the close position, the close solenoid is opened allowing oil to flow to the reservoir at a high flow rate. For positioning applications, the close solenoid is opened until the actuator nears the position set point. At a configurable distance away from the set point, the close solenoid is shut and the slow solenoid is opened to provide an adjustable slow-speed mode for fine positioning. When moving in the close direction while in positioning mode, the bypass valve is opened allowing the motor to run continuously during frequent positioning. This reduces motor starts, increasing motor and contactor life. An accumulator will be fitted if hydraulic stroke speed adjustment is required by the application.

### Double-acting

Double-acting EH actuators include a 4-way, 2-position solenoid valve to control the direction of travel. A stop solenoid is used to keep the actuator in position. A slow-speed solenoid is included for fine positioning near the set point. When energized, the hydraulic fluid is forced through the fixed orifice. An optional accumulator is used to provide stored energy for failsafe operation. Also for failsafe operation, the stop solenoid is changed to a normally open type. An accumulator will also be fitted if hydraulic stroke speed adjustment is required. The dual pilot operated check valves hold the actuator in position upon loss of pressure.

*N.B. These schematics show the basic operation of EH spring-return and double-acting actuators. For simplicity, some items are not shown (i.e., relief valves, filtration, drain valves, and pressure sensing devices). EH actuators operates at high pressure, typically 100 to 170 bar (1,500 to 2,500 psi).*

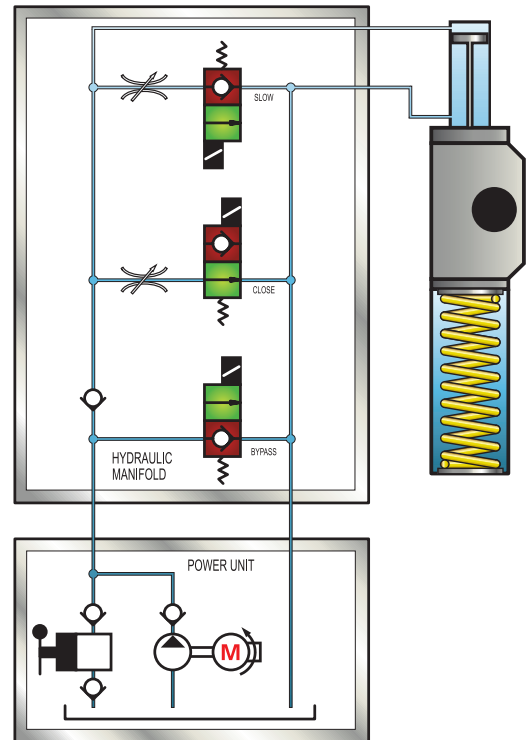

Above: Spring-return.

Below: Double-acting.

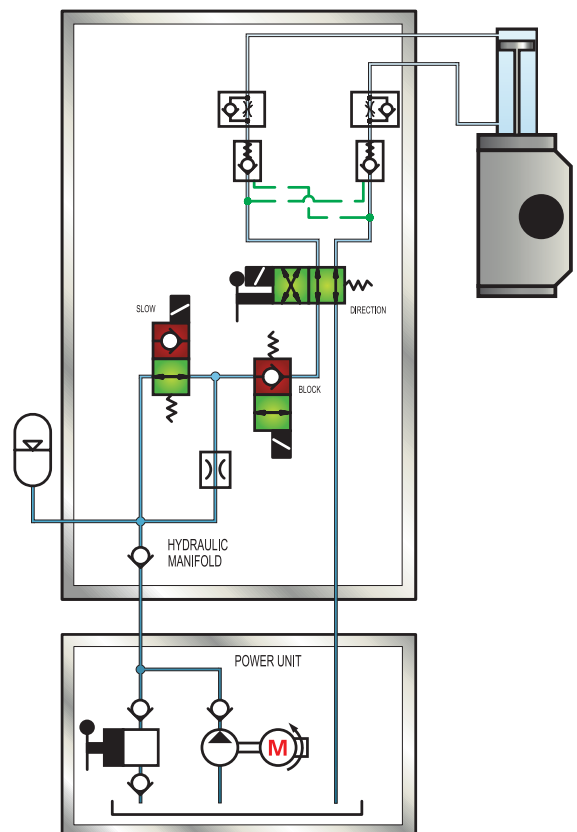



## SB General Purpose Actuators

### SB301/302 – Two-Position

SB actuators offer the simplest solution to spring-return failsafe electric actuation for valve automation. Operating from a standard 230/110 VAC supply, they are designed for general purpose applications with ball and butterfly valves and fire damper. The actuators utilise a fully sealed electro-hydraulic power system with internal spring-return action for clockwise or anti-clockwise rotation.

Skilmatic model SB301/302 general purpose, two-position, quarter-turn actuators are designed for weatherproof applications to IP66/NEMA 4. The actuators provide a torque range of 24 to 480 Nm (212 to 4,248 lbf-in).

See publication PUB021-017 for further details.



### SB405/406 – Modulating

SB405/406 quarter-turn actuators are specifically designed for modulating control but are equally suited for 2-position applications. They accept a standard 4-20 mA or pulsed signal to position a valve or damper with a resolution better than 0.2° and offer a 100% duty rating.

The actuators are housed in a compact and robust weatherproof enclosure to IP65/NEMA 4 to suit all industries and remote valve locations with torque range from 24 to 510 Nm (212 to 4,513 lbf-in).

See publication PUB021-018 for further details.



### SB-1 and SB-2 – Flameproof

SB-1Q and SB-2Q flameproof quarter-turn actuators are designed for two-position and emergency shutdown applications where failsafe spring-return action is required.

Suitable for hazardous areas certified ATEX II 2 G EEx dm IIB T4 (Tamb -35 to +60 °C, Tamb -31 to +140 °F).

The actuators are housed in a compact and robust watertight enclosure to IP67, suitable for a torque range from 65 to 4,400 Nm (575 to 39,000 lbf-in).

See publications PUB021-019 (SB-1) and PUB021-020 (SB-2) for further details.



# Bus Control Systems



## Rotork Pakscan - the total control solution

Whether you need remote control of a few motorised valves, or full automation of a complex plant, Pakscan can help you to achieve significant savings in both time and costs.

Pakscan allows the remote control of actuators and valves over a simple single twisted pair data highway, removing the need for heavy multicore cables. It also includes automatic inbuilt redundancy of the field network to ensure control will be maintained even in the event of equipment or cable failure.

Available as a single or hot standby master station variant, Pakscan has the ability to control up to 240 actuators, and other field devices, using secure field communications. The field data highway cable may be up to 20 km in length so even quite distant valves can easily be incorporated into the network, without the need for repeaters.

Simple to install and simple to use, the highly successful Pakscan system has proved its value on many varied sites with over 70,000 Pakscan actuators installed worldwide.

See publication PUB058-001 for further details.

## Fieldbus Compatibility

In addition to offering full compatibility with Pakscan, SI and EH actuators can be specified to interface seamlessly to many other fieldbus digital control systems. Open fieldbus protocols such as Profibus®, Foundation Fieldbus™, Devicenet® and Modbus® are all available within the SI and EH actuator control options. This is achieved simply and cost effectively through fitting an appropriate Rotork Fluid Systems manufactured circuit board module inside the actuator's electrical housing – normally at the time of production. Module commissioning and setup is carried out using a combination of the Rotork Setting Tool and the network commissioning tools used for the chosen protocol.

An internally mounted Pakscan field unit is used for remote control and status indication over a fault tolerant two-wire serial link. The system has loop distances of up to 20 km without repeaters and host communications using Modbus protocol. System variables are programmable over the infra-red data link.

Rotork Fluid Systems SI and EH Range actuators are fully compatible with the following fieldbus communication. They can also be used in Safety Instrumented Systems (SIS) for remote monitoring when the actuators are supplied with hardwired ESD.

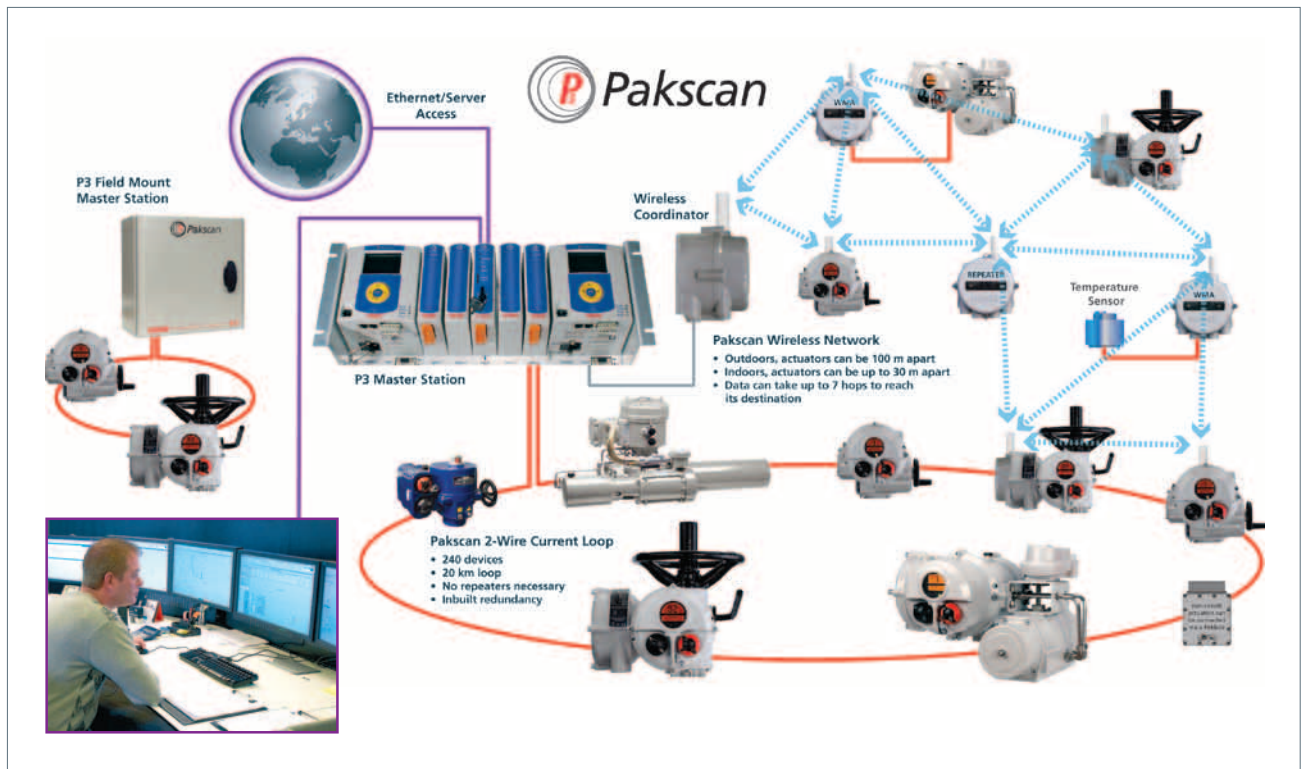

## Industrial Applications

Applications for Skilmatic actuators cover a wide range of industries including oil & gas, power, water, chemical, mining, HVAC and various processing plants. They are ideally suited for remote locations, severe applications where compressed air is not a practical solution, safety critical loops and continuously modulating control. Below is a representative list of typical Skilmatic application.

- Wellhead ESD and choke valve control.
- Pipeline metering pressure control and remote ESD.
- Remote solar power applications.
- Inlet and outlet flow control for fuel storage.
- ESD for fuel storage terminals (ROSoV).
- Modulating control for gas distribution networks and booster stations.
- Tanker loading to optimise and control flow rates.
- Petroleum and hazardous substances road tanker loading ESD.
- Aviation fuel control, fuel line pressure control and ESD.
- Oil and gas refinery fire valves.
- Fire water system pressure control and failsafe distribution valves.
- Hydrocarbon vapour recovery systems.
- Methanol injection control.
- Flare stack ESD and pressure control.
- Modulating control for dosing and blending systems.
- Pump suction and discharge metering facilities.
- Ballast control for floating production vessels.
- Activated sludge aeration tank control WWTP.
- Methane recovery flow and temperature control.
- Filter overflow protection for potable water WTP.
- Water reservoir level control.
- Storm tank overflow protection.
- Feed water control for hydro-electric turbines.
- Tunnel and metro system fire dampers ESD (400 °C).
- Power plant steam and feed water control, damper control, shut-off systems.
- Gas turbine ESD valves.
- Glass manufacturing temperature control.
- Mining and quarry hydrosizer control.



## Industrial Applications

Fire and explosion is a major cause of concern to refinery, gas processing, petro-chemical and offshore installations. Danger and damage from fire can be minimised by the efficient and effective protection of the systems, which control the plant.

For this reason Rotork can recommend a range of fire proofing options for its actuators, ranging from fixed passive protection through to full fire retardant enclosures.

- Semi-Rigid Enclosure System
- Flexible Enclosure System
- Rigid Enclosure System

Fire protection systems allow a Rotork actuator to continue to operate for a significant period of time in fire temperatures of over 1,000 °C (1,832 °F). It is often difficult to draw the line when it comes to protecting equipment against fire.

Whilst this brochure shows examples of fire proofing for Rotork actuators it is essential that valve top works, power and control cables and their entries are also protected.

Rotork Site Services have many years experience with the installation and maintenance of a large variety of fire proofing systems.

### Manual Overrides

Skilmatic actuators are available with optional manual overrides to allow operation of the valve or damper when power to the actuator is not available.

Quarter-turn actuators up to SI-2Q80 are available with manual override gearboxes that mount between the actuator and valve. The handwheel operated gearbox is housed in a cast-iron enclosure which can be supplied with an ISO drive shaft arrangement. Hydraulic manual hand pumps are available for all linear and large quarter-turn actuators.



# General Specification

## Materials

### All SI / EH Actuators

SI / EH power unit:	Aluminium.
Piping:	Stainless steel (Hard piped).
External fasteners:	Stainless steel.
Paint finish:	Standard 2-pack epoxy silver grey or red (150 microns thick).

### SI-1-Q31 to SI-1-Q80

Actuator body:	Aluminium.
Drive shaft:	Plated steel.
Switchbox:	Aluminium.

### SI-2.1-Q100 to SI-2.1-Q112 & EH-Q

Actuator body:	Carbon steel or ductile iron.
Drive shaft:	Carbon steel.
Switchbox:	Aluminium.

### SI-1-L, SI-2-L & EH-L

Actuator body:	Steel.
Piston rod:	Stainless steel.

## Mechanical

### Standard Operating Temperature

SI actuators:	-15 to +60 °C (+5 to +140 °F)*.
EH actuators:	-20 to +40 °C (-4 to +104 °F).

### Optional Low Operating Temperature

SI-1:	-35 to +60 °C (-31 to +140 °F).
SI-2:	-40 to +60 °C (-40 to +140 °F).
EH:	-50 to +60 °C (-58 to +140 °F).

### Watertight Rating

SI:	IP67 – IP68.
EH:	IP54 – IP68.

### Torque / Thrust

See product specification sheets.

### Linear Strokes

Standard up to 105 mm (4"). For optional strokes up to 3,000 mm, consult Rotork Fluid Systems.

### Weight

See product specification sheets.

### Failure Mode

SI:	Failsafe in direction of the spring or fail in last position.
EH:	Failsafe in direction of the spring / accumulator or fail in last position.

### Failsafe Action

Quarter-turn:	Spring / accumulator to act clockwise or anti-clockwise.
Linear:	Spring / accumulator to extend or retract drive shaft.

### Manual Override

SI-1-Q, SI-2.1-Q70/80:	Hydraulic hand pump or gearbox.
SI-2.1-Q110 to Q112:	Hydraulic hand pump.
SI-1-L & SI-2-L:	Hydraulic hand pump.
EH:	Hydraulic hand pump.

### Pressure Measurement

An internal pressure transducer monitors the internal hydraulic system for valve seating and provides an alarm of potential stall conditions. Displayed as a % of maximum generated system pressure, or actual psi / bar.

### Mounting

Vertical or horizontal, see product specification sheets.

## Electrical

### Mains Power Supply

Single-phase:	110, 120, 230 VAC ±10%, 50/60 Hz
Three-phase (SI):	380 to 480 VAC ±10%, 50/60 Hz
Three-phase (EH):	190 to 690 VAC ±10%, 50/60 Hz
DC:	24 VDC

### Power Consumption

See product specification sheets.

### Digital Control (two-position)

Open, Close, Stop / Maintain, Partial stroke and ESD  
20-60 VDC or 20-120 VAC, 5 mA minimum duration 300 ms.

### Analogue Control (modulating)

4-20 mA or 0-10 VDC (adjustable deadband and hysteresis).

### Optional Fieldbus Control

Compatible with Pakscan, Modbus, Profibus, Foundation Fieldbus and DeviceNet. See page 11.

### Position Feedback

4-20 mA, internally or externally powered.

### Resolution

SI:	<0.25% of full scale.
EH:	<0.5% of full scale.

### Repeatability

SI:	<0.2% of full scale.
EH:	<0.5% of full scale.

### Duty Rating

SI:	90%.
EH:	Consult Rotork Fluid Systems.

### Alarm and Monitoring

Relay rating:	Volt free NC or NO contacts rated 5 mA to 5 A 120/230 VAC, 30 VDC.
Monitor relay:	Hardware, local controls, position sensor fault, and EEPROM error.
Alarm and Status relay:	Configured to customer specification for remote alarm or status indication.
SI:	Three relays
EH:	One relay as standard

### Cable Entries

SI:	Four M25/ M20 x 1.5P, adaptors can be fitted for other options.
EH:	Three ½" NPT, adaptors can be fitted for other options.

### Position Measurement

Quarter-turn:	Potentiometer.
Linear:	Potentiometer or transducer.

### Limit Switches

Two switches as standard. Optional four electro mechanical SPDT volt-free switches. Rating 5 A maximum at 230 VAC.

### Local Controls

Lockable Local / Stop / Remote selector switch and Open / Close switch. Totally sealed with internal reed switches.

### Non-Intrusive Setting

Infrared setting via the Rotork Setting Tool.

### Display

Dual Liquid crystal display (LCD) with 32 character text. LEDs for limits and intermediate position.

\* ATEX & IEC certified actuators to +65 °C.



# Hazardous Area Certifications

Every Rotork Fluid Systems actuator is built to provide long and efficient service with a minimum of maintenance. The design, engineering and materials used in the construction ensure optimum performance even in the harshest of environments.

## SI-1 Actuators

**ATEX** - (94/9/EC) II 2G Ex dme\* IIB T4 Gb (Ta: -35 to +65 °C)  
- (94/9/EC) II 2G Ex dme\* IIC T4 Gb (Ta: -20 to +65 °C)

**IECEX** - Ex dme\* IIB T4 Gb (Ta: -35 to +65 °C)  
- Ex dme\* IIC T4 Gb (Ta: -20 to +60 °C)

**FM** - Class I, Zone 1 AEx dme\* IIB T4 (Ta: -35 to +60 °C)  
- Class I, Zone 1 AEx dme\* IIC T4 (Ta: -20 to +60 °C)

**CSA** - Class I, Zone 1 Ex dme\* IIB T4 (Ta: -35 to +60 °C)  
- Class I, Zone 1 Ex dme\* IIC T4 (Ta: -20 to +60 °C)  
(The approval applies only to the power unit. Full actuator assembly will need to be subjected to a CSA inspection)

**GOST** - Ex dme\* IIB T4 (Ta: -35 to +60 °C)  
- Ex dme\* IIC T4 (Ta: -20 to +60 °C)

**INMETRO** - BR-Exdme IIB T4 (Ta: -35 to +60 °C)  
- BR-Exdme IIC T4 (Ta: -20 to +60 °C)

## SI-2 Actuators

**ATEX** - (94/9/EC) II 2G Ex de\* IIB T4 Gb (Ta: -40 to +65 °C)  
- (94/9/EC) II 2G Ex de\* IIC T4 Gb (Ta: -20 to +60 °C)

**IECEX** - Ex de\* IIB T4 Gb (Ta: -40 to +65 °C)  
- Ex de\* IIC T4 Gb (Ta: -20 to +60 °C)

**FM** - Class I, Zone 1 AEx de\* IIB T4 (Ta: -40 to +60 °C)  
- Class I, Zone 1 AEx d\*e IIC T4 (Ta: -20 to +60 °C)

**CSA** - Class I, Zone 1 Ex de\* IIB T4 (Ta: -40 to +60 °C)  
- Class I, Zone 1 Ex de\* IIC T4 (Ta: -20 to +60 °C)

(The approval applies only to the power unit. Full actuator assembly will need to be subjected to a local CSA inspection)

**GOST** - Ex de\* IIB T4 (Ta: -40 to +60 °C)  
- Ex de\* IIC T4 (Ta: -20 to +60 °C)

**INMETRO** - BR-Exde IIB T4 (Tamp: -40 to +60 °C)  
- BR-Exde IIC T4 (Tamp: -20 to +60 °C)

## EH Actuators

**ATEX** - (94/9/EC) II 2G Ex de IIB T4 Gb (Ta: -50 to +60 °C)

**IECEX** - Ex de IIB T4 Gb (Ta: -50 to +60 °C)

**FM** - Explosionproof for Class I, Division 1, Group C & D (Ta: -50 to +60 °C) with UL certified motor.

**FM** - Dust-ignitionproof for Class II, Division 1, Group E, F & G (Ta: -50 to +60 °C) with UL certified motor.

**CSA** - (The full actuator assembly will need to be subjected to a local CSA inspection using a FM power unit).

**GOST** - Ex de IIB T4 (Ta: -40 to +60 °C)

## Setting Tool for SI and EH Actuators

**ATEX** - (94/9/EC) Ex ia IIC T4 Ga (Ta: -30 to +50 °C)

**IEC** - Ex ia IIC T4 Ga (Ta: -30 to +50 °C)

**FM** - Intrinsically Safe for use in Class I, Division 1, Groups A, B, C & D T4 (Ta: -30 to +50 °C)

**CSA** - Ex ia, Class I, Division 1, Groups A, B, C & D (Tamp: -30 to +50 °C)

**GOST** - Ex ia IIC T4 (Ta: -30 to +50 °C)

**INMETRO** - BR-Ex ia IIB T4 (Ta: -30 to +60 °C)

## SB-1 Actuators

**ATEX** - (94/9/EC) Ex dme IIB T4 Gb (Ta: -35 to +60 °C)

**IECEX** - Ex dme\* IIB T4 Gb Gb(Ta: -35 to +60 °C)

**GOST** - Ex dme\* IIB T4 (Ta: -35 to +60 °C)

**INMETRO** - BR-Ex dme IIB T4 (Ta: -35 to +60 °C)

## SB-2 Actuators

**ATEX** - (94/9/EC) Ex de IIB T4 Gb (Ta: -40 to +60 °C)

**IECEX** - Ex de\* IIB T4 Gb (Ta: -40 to +60 °C)

**GOST** - Ex de\* IIB T4 (Ta: -40 to +60 °C)

**INMETRO** - BR-Ex de IIB T4 (Ta: -40 to +60 °C)

\* 'e' increased safety available on single phase & DC supply voltage only. Certification temperatures are not operating temperatures. See specific operating temperature in product specification sheets. See operating temperatures in general specifications.

For full specification see the relevant product specification sheets.

## Rotork Site Services

Rotork Site Services division, bringing together project, service and retrofit activities, is active in 47 service centres in over 20 countries, with agents providing support services in a further 55 countries. The total number of expert technicians supporting Rotork customers is well over 1,000.

The division provides services in maintenance, management and the upgrading of installed actuation assets in order to fully support and satisfy the increasing demands for these activities from customers throughout the world. The services are tailored to meet customers' specific needs, encompassing the following:

### Emergency and Planned Service

Available for all types of actuator, in all areas (including hazardous environments). Some customers require guaranteed emergency response times, others require planned response for all types of actuator work, including installation, commissioning, upgrading, connection and installation of bus communication systems, troubleshooting and repair of damaged or deteriorating assets.

### Actuator Overhauls

After a long service life customers may prefer their actuators to be completely overhauled rather than replacing them with new ones. In our workshops we completely strip and rebuild actuators, returning them to their original state.

### Health Checks

Some customers lack detailed information on their assets, making it difficult to prioritise maintenance and replacement investment. We can carry out a detailed and intrusive inspection of the actuators and combine this with build data from our own databases to give customers a holistic view of their assets.

### Retrofitting actuators to existing valves

We have extensive experience in fitting actuators to valves, penstocks and dampers that are already installed as part of existing plant. Whether customers are replacing obsolete actuators, changing power sources or motorising manual valves, we offer a tailor made solution to meet customers' specific requirements.

### Shutdown Outages

We can support customers in making sure that all their actuators are fully operational and that they meet tight shutdown deadlines. For example some power stations look for us to remove and overhaul in our workshops over 200 actuators when taking a unit out for maintenance. We do this, reinstall and commission the actuators and, where requested, carry out additional actuation projects simultaneously to ensure that customers make the most of their plant shutdown time.

### Preventative Maintenance

We provide regular scheduled maintenance to enhance the integrity of actuators and their associated valves. This service is typically sought by customers looking to maximise the up-time of their plant.

### Factory fitting of actuators to new valves

The careful assembly of valve and actuator is critical to ensure that an automated valve performs correctly and reliably. Whilst this service is often carried out by valve manufacturers, if there is a need we can provide this service.

### Extended scope projects

This is a growing requirement and some of our service teams have the wide range of skills necessary to offer a "one-stop-shop" to automate part or all of a customer's process. Our capabilities cover all of the installation phases (scoping, design, procurement, manufacturing, installation, commissioning) on the broad scopes that typically surround actuation projects.



## Case Study

# Rotork provides electric solutions for automated flow control at the Botlek Tank Terminal

***The Botlek Tank Terminal (BTT) at Rotterdam relies on Rotork's latest electric valve actuation technologies for automated flow control and vital safety related duties associated with the import, export and storage of a varied range of liquid bulk products.***

Construction of the €70 million first phase of the terminal began in April 2010 and was completed within budget and on time by the Polish company Polimex-Mostostal S.A. BTT has 34 storage tanks, providing a combined storage capacity of 200,000 cubic metres, of which 130,000 cubic metres is earmarked for clean fuels and the rest is for edible oils and biodiesel. The state-of-the-art terminal has deepwater berths including a 420 metre jetty that can simultaneously accommodate two seagoing vessels and two barges, operating 24 hours-a-day.

Over 250 Rotork IQPro multi-turn and quarter-turn intelligent electric actuators have been installed to operate the valves that control the routine movement of liquids throughout the site. A further 55 Rotork Skilmatic SI self-contained electro-hydraulic actuators have been installed in strategic areas on valves that provide failsafe Emergency Shutdown (ESD) protection from potential accidents and spillages. All the Rotork actuators are monitored and controlled on fully redundant Rotork Pakscan digital bus loops, linked by three Pakscan P3 master stations to the site's central SCADA system.

The Skilmatic SI actuators are equipped with integral circuitry designed to receive a separately hardwired discrete ESD alarm signal that will override any other input and move the actuator to the pre-determined safe position, even in the event of electrical power failure. These actuators are situated on the inlet and outlet ports of the storage tanks and on the marine and truck loading bays. They are key components in the Safety

Instrumented System (SIS) that operates with dedicated level and flow sensors and ESD logic solvers to provide the site's Safety Instrumented Function (SIF).

BTT General Manager Charles Smisssaert pointed out that the Rotork Skilmatic electro-hydraulic solution for ESD protection at the site had been selected as a more robust and reliable alternative to air operated actuators, which also require more maintenance.

All Rotork actuators at BTT feature ATEX explosionproof certification and IP68 double-sealed watertight enclosures designed for harsh and exposed environments. They also share Rotork's IQPro non-intrusive setting, commissioning and data communication technologies, enabling actuator configuration and data logger files to be transferred from the field to the office for diagnostics, analysis and storage. In combination with Rotork IQ-Insight software, this data can help to maximise plant utilisation by identifying potential valve wear problems and facilitating predictive maintenance.

The punctual completion of the tank farm was assisted by the nearby presence of Rotork BV's fully equipped

workshop, which provided the facilities to motorise all the valves, encompassing gate and butterfly designs in sizes up to 16 inches, before shipping them to site as complete, factory tested packages. Rotork also assisted with installation and commissioning and will continue to provide local support for all the installed actuators.





Electric Actuators and Control Systems  
Fluid Power Actuators and Control Systems  
Gearboxes and Gear Operators  
Precision Control Instruments  
Projects, Services and Retrofit



*Corporate headquarters*  
Rotork plc  
*tel* +44 (0)1225 733200  
*fax* +44 (0)1225 333467  
*email* mail@rotork.com

A full listing of our worldwide sales and service network is available on our website.

[www.rotork.com](http://www.rotork.com)

PUB021-001-00  
Issue 04/12

As part of a process of on-going product development, Rotork reserves the right to amend and change specifications without prior notice. Published data may be subject to change. For the very latest version release, visit our website at [www.rotork.com](http://www.rotork.com)

The name Rotork is a registered trademark. Rotork recognises all registered trademarks. Published and produced in the UK by Rotork Controls Limited. POWTG0412